



TM

Bigblue RANGE COOKERS

INSTALLATION INSTRUCTIONS AND USER GUIDE

Select 70df Twin

ISSUE A

CONTENTS

Page Number

Introduction	3
Important Safety Precautions and Recommendations	4-6
Cooking Hob	7
Control Panel	8
Electronic Programmer	9 - 13
How to Use of Hob Burners	14 - 15
How to Use the Fan Oven	16 - 18
How to Use the Convection Oven	19 - 21
Cooking Guide	22
Cleaning and Maintenance	23 - 32
Advice For The Installer	33
Installation	34 - 38
Gas Installation	39 - 44
Electrical Installation	45 - 46

Introduction

Dear Customer,

Thank you for having purchased and given your preference to our product.

The safety precautions and recommendations reported below are for your own safety and that of others. They will also provide a means by which to make full use of the features offered by your appliance.

Please preserve this booklet carefully. It may be useful in future, either to yourself or to others in the event that doubts should arise relating to its operation.

This appliance must be used only for the task it has explicitly been designed for, that is for cooking foodstuffs. Any other form of usage is to be considered as inappropriate and therefore dangerous.

The manufacturer declines all responsibility in the event of damage caused by improper, incorrect or illogical use of the appliance.

DECLARATION OF CE CONFORMITY

This cooker has been designed, constructed, and marketed in compliance with:

- Safety requirements of EU Directive “Gas” 2009/142/EC;
- Safety requirements of EU Directive “Low Voltage” 2006/95/EC;
- Protection requirements of EU Directive “EMC” 2004/108/EC;
- Requirements of EU Directive 93/68/EEC;
- Requirements of EU Directive 2011/65/EU.



IMPORTANT INFORMATION FOR CORRECT DISPOSAL OF THE PRODUCT IN ACCORDANCE WITH EC DIRECTIVE 2002/96/EC.

At the end of its working life, the product must not be disposed of as urban waste. It must be taken to a special local authority differentiated waste collection centre or to a dealer providing this service.

Disposing of a household appliance separately avoids possible negative consequences for the environment and health deriving from inappropriate disposal and enables the constituent materials to be recovered to obtain significant savings in energy and resources. As a reminder of the need to dispose of household appliances separately, the product is marked with a crossed-out wheeled dustbin.

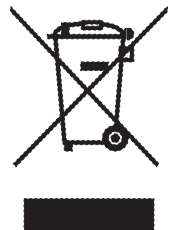

IMPORTANT SAFETY PRECAUTIONS AND RECOMMENDATIONS

IMPORTANT: This appliance is designed and manufactured solely for the cooking of domestic (household) food and is not suitable for any non domestic application and therefore should not be used in a commercial environment.

The appliance guarantee will be void if the appliance is used within a non domestic environment i.e. a semi commercial, commercial or communal environment.

Read the instructions carefully before installing and using the appliance.

- After having unpacked the appliance, check to ensure that it is not damaged and that the oven door closes correctly.
In case of doubt, do not use it and consult your supplier or a professionally qualified technician.
- Packing elements (i.e. plastic bags, polystyrene foam, nails, packing straps, etc.) should not be left around within easy reach of children, as these may cause serious injuries.
- Some appliances are supplied with a protective film on steel and aluminium parts. **This film must be removed before using the appliance.**
- **IMPORTANT:** The use of suitable protective clothing/gloves is recommended when handling or cleaning of this appliance.
- Do not attempt to modify the technical characteristics of the appliance as this may become dangerous to use. The manufacturer declines all responsibility for any inconvenience resulting from the inobservance of this condition.
- **CAUTION:** this appliance must only be installed in a permanently ventilated room in compliance with the applicable regulations.
- Do not carry out cleaning or maintenance operations on the appliance without having previously disconnected it from the electric power supply.
- **WARNING:** Ensure that the appliance is switched off before replacing the oven lamp to avoid the possibility of electric shock.
- Do not use a steam cleaner because the moisture can get into the appliance thus make it unsafe.

- Do not touch the appliance with wet or damp hands (or feet).
- Do not use the appliance whilst in bare feet.
- If you should decide not to use this appliance any longer (or decide to substitute another model), before disposing of it, it is recommended that it be made inoperative in an appropriate manner in accordance to health and environmental protection regulations, ensuring in particular that all potentially hazardous parts be made harmless, especially in relation to children who could play with unused appliances.
- The various components of the appliance are recyclable. Dispose of them in accordance with the regulations in force in your country. If the appliance is to be scrapped, remove the power cord.
- After use, ensure that the knobs are in the off position.
- Children less than 8 years of age shall be kept away unless continuously supervised.
- This appliance can be used by children aged from 8 years and above and persons with reduced physical, sensory or mental capabilities or lack of experience and knowledge if they have been given supervision or instruction concerning use of the appliance in a safe way and understand the hazards involved. Children shall not play with the appliance. Cleaning and user maintenance shall not be made by children without supervision.
- The manufacturer declines all liability for injury to persons or damage to property caused by incorrect or improper use of the appliance.
- **WARNING:** During use the appliance and its accessible parts become hot; they remain hot for some time after use.
 - Care should be taken to avoid touching heating elements (on the hob and inside the oven).
 - The door is hot, use the handle.
 - To avoid burns and scalds, young children should be kept away.
- Make sure that electrical cables connecting other appliances in the proximity of the cooker cannot come into contact with the hob or become entrapped in the oven door.
- **WARNING:** Unattended cooking on a hob with fat or oil can be dangerous and may result in fire. NEVER try to extinguish a fire with water, but switch off the appliance and then cover flame e.g. with a lid or a fire blanket.

- **WARNING:** Danger of fire: do not store items on the cooking surfaces.
- **WARNING:** When correctly installed, your product meets all safety requirements laid down for this type of product category. However special care should be taken around the rear or the underneath of the appliance as these areas are not designed or intended to be touched and may contain sharp or rough edges, that may cause injury.
- **FIRST USE OF THE OVEN** - it is advised to follow these instructions:
 - Furnish the interior of the oven as described at chapter “CLEANING AND MAINTENANCE”.
 - Switch on the empty oven on max to eliminate grease from the heating elements.
 - Disconnect the appliance from the electrical power supply, let the oven cool down and clean the interior of the oven with a cloth soaked in water and neutral detergent; then dry carefully.
- **CAUTION:** Do not use harsh abrasive cleaners or sharp metal scrapers to clean the oven door glass since they can scratch the surface, which may result in shattering of the glass.
- Do not line the oven walls with aluminium foil. Do not place baking trays or the drip tray on the base of the oven chamber.
- **FIRE RISK!** Do not store flammable material in the oven or in the storage compartment.
- Always use oven gloves when removing the shelves and food trays from the oven whilst hot.
- Do not hang towels, dishcloths or other items on the appliance or its handle – as this could be a fire hazard.
- Clean the oven regularly and do not allow fat or oils to build up in the oven base or tray. Remove spillages as soon as they occur.
- Do not stand on the cooker or on the open oven door.
- Always stand back from the appliance when opening the oven door to allow steam and hot air to escape before removing the food.
- **SAFE FOOD HANDLING:** Leave food in the oven for as short a time as possible before and after cooking. This is to avoid contamination by organisms which may cause food poisoning. Take particular care during warmer weather.
- **WARNING:** Taking care NOT to lift the cooker by the door handle.

Fig. 1.1

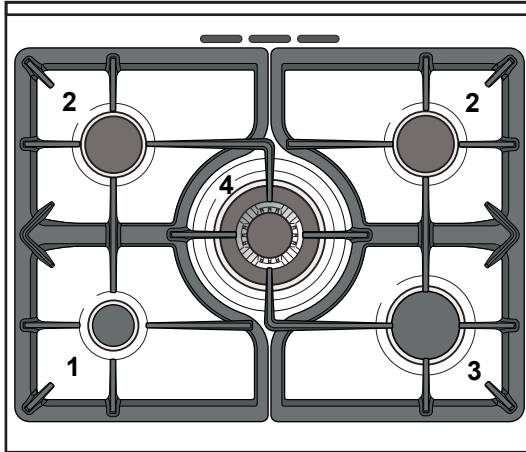

GAS BURNERS

- | | |
|----------------------------|---------|
| 1. Auxiliary burner (A) | 1,00 kW |
| 2. Semi-rapid burner (SR) | 1,75 kW |
| 3. Rapid burner (R) | 3,00 kW |
| 4. Triple-ring burner (TR) | 3,50 kW |

Notes:

- The electric ignition is incorporated in the knobs.
- The appliance has a safety valve system fitted, the flow of gas will be stopped if and when the flame should accidentally go out.

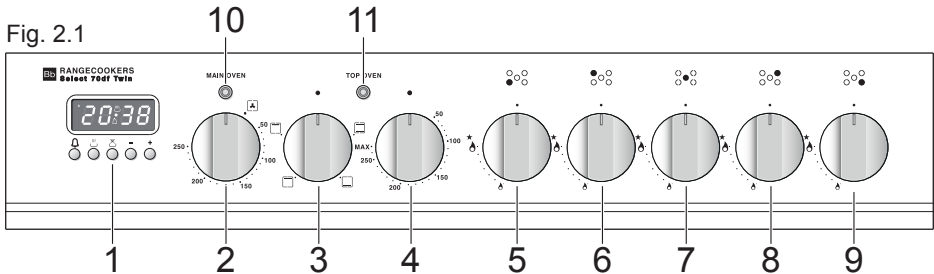

CONTROL PANEL - Controls description

1. Electronic programmer (bottom main oven only)
2. Fan oven switch/thermostat control knob (bottom main oven)
3. Conventional oven switch control knob (top oven)
4. Conventional oven thermostat control knob (top oven)
5. Front left auxiliary burner control knob
6. Rear left semi-rapid burner control knob
7. Central triple-ring burner control knob
8. Rear right semi-rapid burner control knob
9. Front right rapid burner control knob

Pilot lamps:

10. Fan oven temperature indicator light
11. Conventional oven on indicator light

Please note: This appliance incorporates a safety cooling fan which you will hear operating whenever the oven or grill is being used.

The cooling fan may even run on after the appliance has been switched off.







The duration of this time is dependent on several factors, including previous cooking temperature, duration and ambient temperature. Times in excess of 30 minutes are not on common.

3 Electronic Programmer (bottom main oven only)



The electronic programmer is a device which groups together the following functions:

- 24 hours clock with illuminated display
- Timer (up to 23 hours and 59 minutes)
- Program for automatic oven cooking
- Program for semi-automatic oven cooking

Description of the buttons:

-  Timer
-  Cooking time
-  End of cooking time
-  Simultaneously: Switching to manual and program reset.
-  To increase the numbers on the digital display
-  To decrease the numbers on the digital display.

Description of the illuminated symbols:

- A** flashing - Programmer in automatic position but not programmed
- A** illuminated - Programmer in automatic position with program inserted.
-  Automatic cooking taking place
-  Timer in operation
-  and **A** - flashing - Program error. (The time of day lies between the calculated cooking start and end time).

Note:

Select a function by the respective button and, in 5 seconds, set the required time with the **+** / **-** buttons ("one-hand" operation).

After a power cut the display resets to zero and cancels the set programs.

Caution: If the electricity supply is cut off (the display numbers will flash), the clock will reset and all the programs entered will be cancelled.

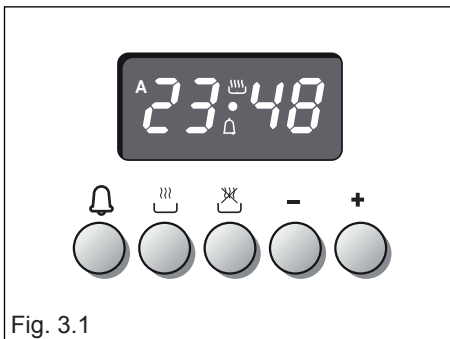





Fig. 3.1

SETTING TIME OF DAY (fig. 3.2)



The programmer is provided with an electronic clock with luminous figures showing the hour and minutes.

The first time the oven is connected up to the electricity supply and after a power cut, three zeroes will flash on the programmer display.



To adjust the time, the two buttons   must be pressed simultaneously and then the button  or  until the correct time is set.

Setting speed automatically increases if you keep the setting buttons pressed.

MANUAL OPERATION

To use the oven manually, i.e. without the programmer, you must cancel the flashing **A** by pressing the two buttons   simultaneously (the letter **A** will go out and the symbol  will come on).

CANCELLING A PROGRAMME



If the letter **A** is not flashing (which means that a cooking program has already been set) by pressing the two buttons   simultaneously you will cancel the program and switch to manual.

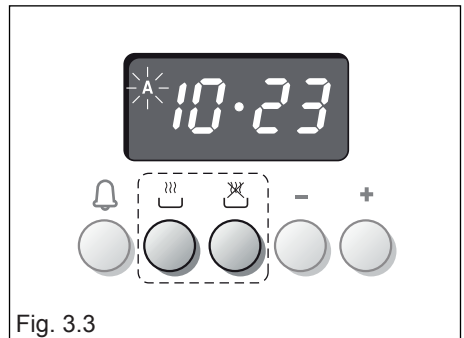
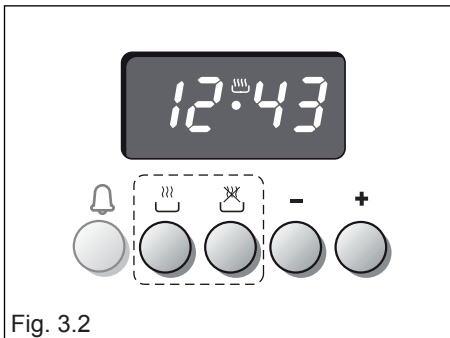

If the oven is on, you must switch it off manually.



MINUTE MINDER

The minute counter function consists simply of an acoustic signal which can be set for a maximum of 23 hours 59 minutes.

If the letter **A** is flashing, press the two buttons   simultaneously.

To set the time, press button  and then button  or  until the required time appears on the display (fig. 3.4).

The symbol  will come on.

Countdown will begin immediately and can be seen on the display at any time by simply pressing button .

When the time expires, the symbol  will go out and an intermittent acoustic signal will come on which can be switched off by pressing any of the buttons.

AUDIBLE SIGNAL

The audible signal sounds at the end of a minute minder cycle or of a cooking programme for a period of 7 minute.

The signal can be cancelled by pressing any function button.

Pressing the  button without having previously selected a function the frequency of the signal change. You can choose from three variations.

The selected signal is audible as long as the button  is pressed.

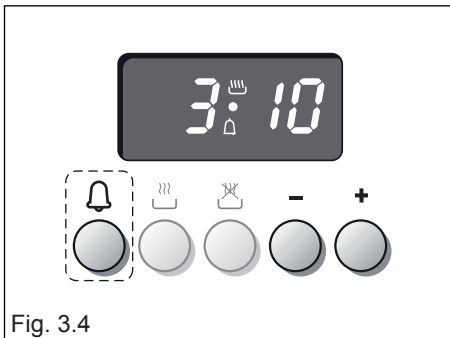

Fig. 3.4

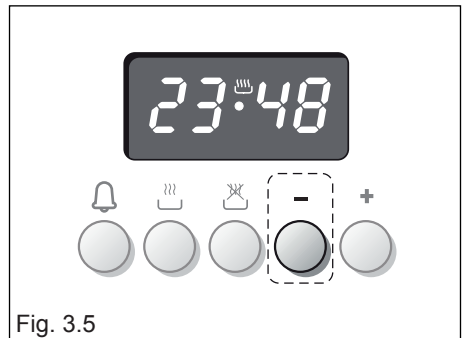





Fig. 3.5

SEMI - AUTOMATIC COOKING



This automatically switches the oven off after the required cooking time. There are two methods of semi-automatic cooking:

1° METHOD: Programming the cooking time (fig. 3.6)

- Set the cooking time by pressing button  and then button  to move forward or  to move back if you have gone beyond the required time.

The letter **A** and the symbol  will appear.



2° METHOD: Programming the end of cooking time (fig. 3.7)



- Set the end of cooking time by pressing button  and then button  to move forward or  to move back if you have gone beyond the required time.

The letter **A** and the symbol  will appear.



Having programmed according to one of the above methods, set the temperature and function via the function selector and thermostat knob (see specific chapters).



The oven will come on immediately and when the set time or programmed end of cooking time expires, it will automatically switch off.



During cooking the letter **A** and the symbol  remains on; press button  to display the remaining time until end of cooking or press button  to display the end of cooking time.

The cooking program can be cancelled at any time by pressing the two buttons   simultaneously.

At the end of cooking, turn the oven knob to the off position the  symbol will go out. The letter **A** will flash and the acoustic signal will come on - this can be switched off by pressing any of the buttons.

Reset the function selector and thermostat knob and set the programmer to manual by pressing the two buttons   simultaneously.

Important: Also if oven is turned off automatically by the programmer, remember to turn to the off position the function selector and the thermostat knob. If not, when pressing two buttons   simultaneously for manual use, the oven will start to operate.

Remember to press the two buttons   simultaneously to be able to use the oven in manual setting.

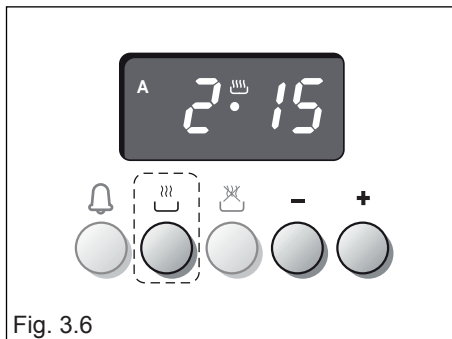

Fig. 3.6

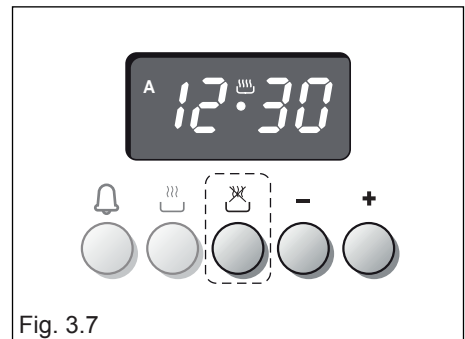





Fig. 3.7

AUTOMATIC COOKING

To cook in the oven in automatic mode follow the instructions below:



1. Set the cooking time
2. Set the end of cooking time
3. Set the cooking temperature and function

These operations are carried out as follows:

1. Set the cooking time by pressing button  and then  to move forward or  to move back if you have gone beyond the required time (fig. 3.8).

The letter **A** and the symbol  appear.

2. Press button ; the cooking time already added to the clock time appear.

Set the end of cooking time by pressing button  if you go beyond the required time, you can go back by pressing button .



The symbol  go out and the letter **A** remains on (fig. 3.9).



If during the setting the letter **A** begins to flash on the display and the acoustic signal comes on, this indicates a programming error, i.e. the cooking cycle has been superimposed on the clock time. In this case alter the end of cooking time or the cooking time as above.



3. Set the cooking temperature and function via the function selector and thermostat knob (see specific chapters).



The oven is now programmed and everything will work automatically; the oven will come on as required and finish cooking at the programmed time.



At the start of the cooking the symbol  appear.

During cooking the letter **A** and the symbol  remains on; press button  to display the remaining time until end of cooking or press button  to display the end of cooking time.

The cooking program can be cancelled at any time by pressing the two buttons   simultaneously.

At the end of cooking, the oven switch off, the symbol  go out, the letter **A** flash and the acoustic signal come on - this can be switched off by pressing any of the buttons. Reset the function selector and thermostat knob and set the programmer to manual by pressing the two buttons   simultaneously.

Important: Also if oven is turned off automatically by the programmer, remember to turn to the off position the function selector and the thermostat knob. If not, when pressing two buttons   simultaneously for manual use, the oven will start to operate.

Remember to press the two buttons   simultaneously to be able to use the oven in manual setting.

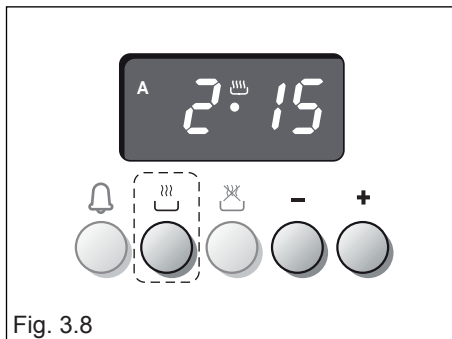

Fig. 3.8

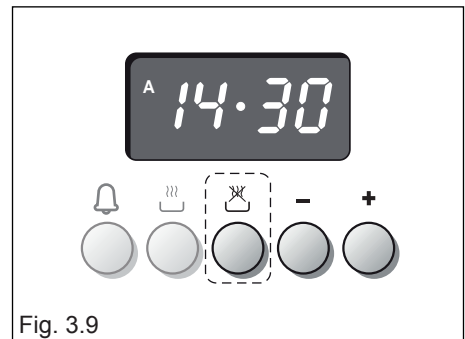





Fig. 3.9

GAS BURNERS

Gas flow to the burners is adjusted by turning the knobs (illustrated in fig. 4.1) which control the safety valves.

Turning the knob, so that the indicator line points to the symbols printed on the panel, achieves the following functions:

- symbol  closed valve
- symbol  maximum aperture or flow
- symbol  minimum aperture or flow

- √ The maximum aperture position permits rapid boiling of liquids, whereas the minimum aperture position allows slower warming of food or maintaining boiling conditions of liquids.
- √ To reduce the gas flow to minimum rotate the knob further anti-clockwise to point the indicator towards the small flame symbol.
- √ Other intermediate operating adjustments can be achieved by positioning the indicator between the maximum and minimum aperture positions, and never between the maximum aperture and closed positions.

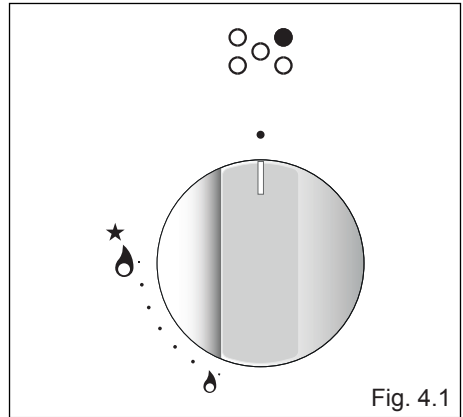

Fig. 4.1

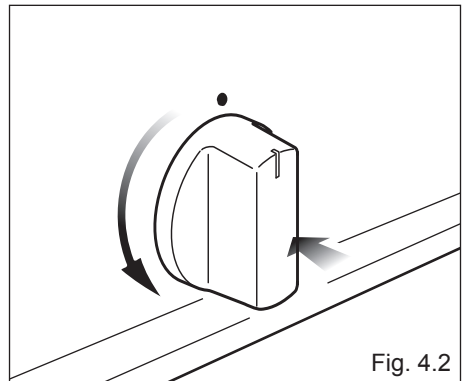

Fig. 4.2



Caution!

The cooking hob becomes very hot during operation.
Keep children well out of reach.

N.B. When the cooker is not being used, set the gas knobs to their closed positions.

LIGHTING THE BURNERS

To ignite the burner, the following instructions are to be followed:

1. Press in the corresponding knob and turn counter-clockwise (fig. 4.2) to the  full flame position marked by the  symbol (fig. 4.1); hold the knob in until the flame has been lit.
In the case of a mains failure light the burner with a match or lighted taper.
2. Wait for a few seconds after the gas burner has been lit before letting go of the knob (valve activation delay).
3. Adjust the gas valve to the desired position.

If the burner flame should go out for some reason, the safety valve will automatically stop the gas flow.

To re-light the burner, return the knob to the closed  position, **wait for at least 1 minute** and then repeat the lighting procedure.

If your local gas supply makes it difficult to light the burner with the knob set to maximum, set the knob to minimum and repeat the operation.

CHOICE OF THE BURNER

On the control panel, near every knob there is a diagram that indicates which burner is controlled by that knob.

The suitable burner must be chosen according to the diameter and the capacity used.

As an indication, the burners and the pots must be used in the following way:

DIAMETERS OF PANS WHICH MAY BE USED ON THE BURNERS		
BURNERS	MINIMUM	MAXIMUM
Auxiliary	12 cm	14 cm
Semi-rapid	16 cm	24 cm
Rapid	24 cm	26 cm
Triple-ring	26 cm	28 cm

do not use pans with concave or convex bases

It is important that the diameter of the pot be suitable to the potentiality of the burner so as not to compromise the high output of the burners and therefore energy waste. A small pot on a large burner does not give you a boiling point in a shorter amount of time since the capacity of heat absorption of a liquid mass depends on the volume and the surface of the pot.

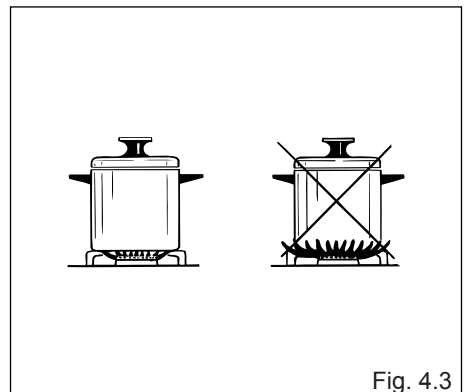

Fig. 4.3

5

How to Use the Fan Oven (Bottom Main Oven)

WARNING:

The door is hot, use the handle.

During use the appliance becomes hot. Care should be taken to avoid touching heating elements inside the oven.

Attention: The oven door becomes very hot during operation. Keep children away.

GENERAL FEATURES

Fan cooking is more economical and quicker than cooking in a conventional oven. The moving hot air surrounds the food and penetrates it more quickly than in a conventional oven.

The oven is equipped with a circular element (2200 W) and a fan.

Note:

Upon first use, it is advisable to operate the oven at the maximum temperature (thermostat knob on position 250) for 60 minutes to eliminate any traces of grease from the electrical element.

Smells and fumes produced during this burn off process are not a cause of alarm. Adequate ventilation should however be provided in the room where the appliance is installed, e.g. by opening a window.

OPERATING PRINCIPLES

Heating and cooking in this oven are obtained by forced convection.

A fan sucks in the air contained in the oven muffle, which sends it through the circular heating element and then sends it back through the muffle. Before the hot air is sucked back again by the fan to repeat the described cycle, it envelops the food in the oven, provoking a complete and rapid cooking.

It is possible to cook several dishes simultaneously.

IMPORTANT

To open the bottom door operate as indicated in fig. 5.1.

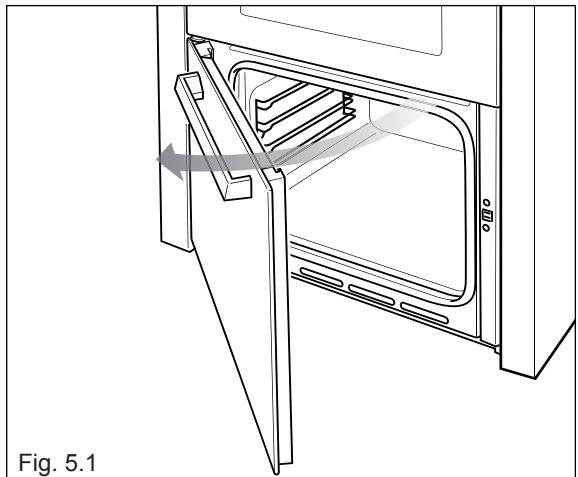

Fig. 5.1

SWITCH / TEMPERATURE SELECTOR

Rotate the knob clockwise to set the oven for one of the following functions:



Off as per fig. 5.2

Only the oven fan is on.

The fan operates without the heating element, this function can be used for defrosting.

50 TO 250

The oven light is switched on.

The oven temperature can be set between 50°C - 250°C.

The set temperature has been reached when the temperature indicator light goes off.

Several different meals may be cooked simultaneously on various shelves, as the heated air circulates evenly throughout the oven.

The hot air system cooks more quickly than conventional static system, therefore the temperature should be set 15°C - 20°C below the values recommended in your recipe books.

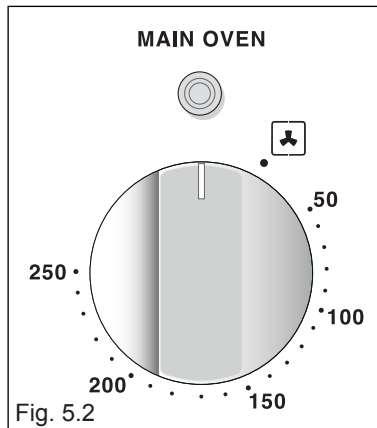

COOKING ADVICE

STERILIZATION

Sterilization of foods to be conserved, in full and hermetically sealed jars, is done in the following way:

- a. Set the selector knob to position 185 °C and preheat the oven.
- b. Fill the dripping pan with hot water.
- c. Set the jars onto the dripping pan making sure they do not touch each other and the door and set the knob to position 135 °C. When sterilization has begun, that is, when the contents of the jars start to bubble, turn off the oven and let cool.

REGENERATION

Set the selector knob to position 150° C.

Bread becomes fragrant again if wet with a few drops of water and put into the oven for about 10 minutes at the highest temperature.

ROASTING

To obtain classical roasting, it is necessary to remember:

- that it is advisable to maintain a temperature between 180° and 200 ° C.
- that the cooking time depends on the quantity and the type of foods.

OVEN COOKING

Before introducing the food, preheat the oven to the desired temperature.

For a correct preheating operation, it is advisable to remove the tray from the oven and introduce it together with the food, when the oven has reached the desired temperature.

Check the cooking time and turn off the oven 5 minutes before the theoretical time to recuperate the stored heat.

SIMULTANEOUS COOKING OF DIFFERENT FOODS

The fan consents a simultaneous heterogeneous cooking of different foods. Different foods such as fish, cake and meat can be cooked together without mixing the smells and flavours together. This is possible since the fats and vapours are oxidized while passing through the electrical element and therefore are not deposited onto the foods.

The only precaution to follow are:

- The cooking temperatures of the different foods must be as close to as possible, with a maximum difference of 20° - 25 °C.
- The introduction of the different dishes in the oven must be done at different times in relation to the cooking times of each one.
- The time and energy saved with this type of cooking is obvious.

6 HOW TO USE THE CONVECTION OVEN (TOP OVEN)

WARNING:

The door is hot, use the handle.

During use the appliance becomes hot. Care should be taken to avoid touching heating elements inside the oven.

Attention: The oven door becomes very hot during operation. Keep children away.

GENERAL FEATURES



The convection oven is equipped with 3 electrical heating elements:

- 2 elements (upper and lower) for normal oven cooking;
- 1 grill element, on the top of the oven, for grilling which must be done with the oven door closed.

The input of the elements is:

- Upper element 700 W
- Lower element 1000 W
- Grill element 2000 W

Note:

Upon first use, it is advisable to operate the oven at the maximum temperature (thermostat knob on position MAX) for 60 minutes in the position  and for another 15 minutes in the  mode in order to eliminate any traces of grease from the electrical resistances.

OPERATING PRINCIPLES

Heating and cooking in the CONVENTIONAL oven are obtained in the following ways:

a. by normal convection

The heat is produced by the upper and lower heating elements.

b. by radiation

The heat is radiated by the infra red grill element (use with the oven door closed).

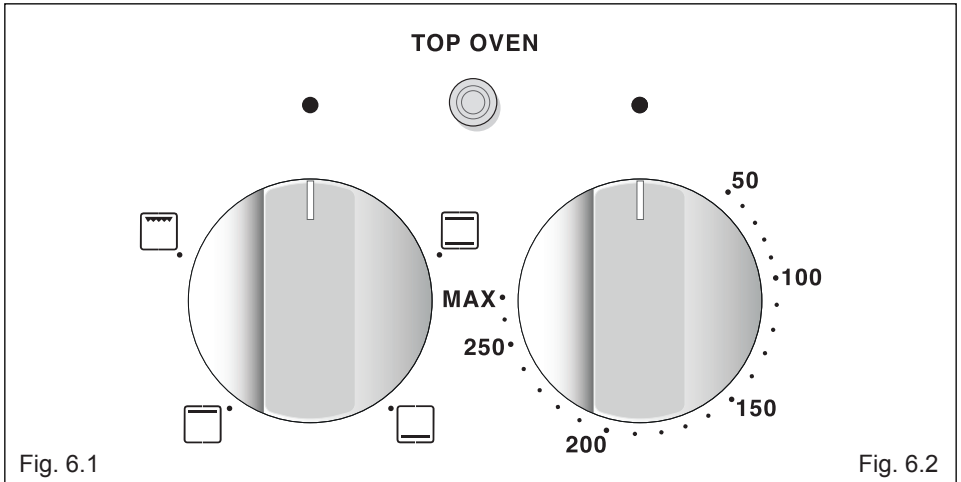

THERMOSTAT KNOB (fig. 6.2)

This only sets the cooking temperature and does not switch the oven on. Rotate clockwise until the required temperature is reached (from 50° C to MAX). The light between the thermostat and the function selector will illuminate when the oven is switched on.

FUNCTION SELECTOR KNOB (fig. 6.1)

Rotate the knob clockwise to set the oven for one of the following functions.

OVEN LIGHT

The oven is equipped with a light that illuminates the oven to enable visually controlling the food that is cooking.

This light is controlled by the function selector knob (fig. 6.1).

It remains on in all the cooking modes.



TRADITIONAL CONVECTION

The upper and lower heating elements are switched on. The heat is diffused by natural convection and the temperature must be regulated between 50° C and MAX position with the thermostat knob.

It is necessary to preheat the oven before introducing the foods to be cooked.

Recommended for:

For foods which require the same cooking temperature both internally and externally, i. e. roasts, spare ribs, meringue, etc.



LOWER HEATING ELEMENT

In this position only the lower element is switched on. Heat is distributed by natural convection. The thermostat can be set between 50 and 150°C; higher temperatures are not available.

Recommended for:

This mode is particularly suitable to complete cooking of dishes that require higher temperature at the bottom.



UPPER HEATING ELEMENT

In this position only the upper element is switched on. Heat is distributed by natural convection. The thermostat can be set between 50 and 150°C; higher temperatures are not available.

Recommended for:

This mode is particularly suitable to complete cooking of dishes that require higher temperature at the top.



GRILLING

The infra-red heating element is switched on. The heat is diffused by radiation.

Use with the oven door closed and the thermostat knob to between 50°C and 200°C.

For correct use see chapter "USE OF THE GRILL".

Before using the grill, preheat for about five minutes.

Always grill with the oven door closed and do not use the grill for longer than 30 minutes at any one time.

Caution: The oven door becomes very hot during operation.

Keep children well out of reach.

Recommended for:

Intense grilling action for cooking with a broiler; browning, crisping, "au gratin", toasting, etc.

USE OF THE GRILL

Leave to warm up for approximately 5 minutes with the door closed. Place the food inside positioning the rack as near as possible to the grill. Insert the drip pan under the rack to collect the cooking juices.

Grilling with the oven door closed and do not for longer than 30 minutes at any one time.

Attention: the oven door becomes very hot during operation. Keep children away.

OVEN COOKING

Before introducing the food, preheat the oven to the desired temperature.

For a correct preheating operation, it is advisable to remove the tray from the oven and introduce it together with the food, when the oven has reached the desired temperature.

Check the cooking time and turn off the oven 5 minutes before the theoretical time to recuperate the stored heat.

Cooking process	Oven heat	Gas mark	Electric oven temperature	
			°C	°F
Keeping food hot, milk puddings	very cool	½	120	250
Egg custards	cool	1	140	275
Rich fruit cakes, braising	cool	2	150	300
Low temperature roasting, shortbread	moderate	3	160	325
Victoria sandwich, plain fruit cake, baked fish	moderate	4	180	350
Small cakes, choux pastry	fairly hot	5	190	375
Short pastry, Swiss rolls, soufflés	fairly hot	6	200	400
High temperature roasting, flaky pastry, scones	hot	7	220	425
Puff pastry, bread	very hot	8	230	450
Small puff pastries, browning cooked foods	very hot	9	240	475

These temperatures relate to the centre oven temperature.

Remember to use ovenproof dishes and to adjust the oven temperature during cooking if necessary.

NOTE: Reduce the oven temperature by 10 – 20°C for fan assisted ovens. For dishes that take over an hour to cook, reduce the cooking time by 10 minutes per hour.

GENERAL ADVICE

- **Before you begin cleaning, you must ensure that the appliance is switched off at the cooker switch.**
- The periodical lubrication of the gas taps must be done only by specialized personnel.
- If a tap becomes stiff, do not force; contact your local After Sales Service Centre.
- It is advisable to clean when the appliance is cold and especially when cleaning the enamelled parts.
- Avoid leaving alkaline or acidic substances (lemon juice, vinegar, etc.) on the surfaces.
- **Avoid using cleaning products with a chlorine or acidic base.**
- **Important: The use of suitable protective clothing/gloves is recommended when handling or cleaning this appliance.**
- **Under no circumstances should any external covers be removed for servicing or maintenance except by suitable qualified personnel.**

WARNING:

When correctly installed, your product meets all safety requirements laid down for this type of product category. However special care should be taken around the rear or the underneath of the appliance as these areas are not designed or intended to be touched and may contain sharp or rough edges, that may cause injury.

Attention!

The appliance gets very hot, mainly around the cooking areas. It is very important that children are not left alone in the kitchen when you are cooking.

Do not use a steam cleaner because the moisture can get into the appliance thus make it unsafe.

Do not use harsh abrasive cleaners or sharp metal scrapers to clean the oven door glass since they can scratch the surface, which may result in shattering of the glass.

CLEANING

- **Stainless steel hob:** Spillage on the hob can usually be removed by a damp soapy cloth. More obstinate stains can be removed by using a proprietary stainless steel cleaning product that does not contain chlorine or acidic base.
- **Control panel facia:** Clean very carefully with water and neutral soap; the cloth used must be rinsed well and must be free of any cleaning chemicals to avoid damaging any screen print on the facia.
- **Door, glass & painted surfaces:** Clean very carefully with water and neutral soap; the cloth used must be rinsed well and must be free of any cleaning chemicals.
- **Pan stands & burner caps:** Clean with a sponge and soapy water or proprietary cream cleaner. Always dry thoroughly. **DO NOT PUT IN THE DISHWASHER.**
- **Burner bodies (aluminium alloy):** They should be cleaned with soapy water and a clean cloth. For stubborn stains a proprietary cream or stainless steel cleaner may be used; however to maintain an uniform finish we would recommend the whole area is cleaned. **NOTE:** Please ensure the slots/castellations are kept free of the any material/cleaner.

- **Inside of oven:** The oven should always be cleaned after use when it has cooled down. The cavity should be cleaned using a mild detergent solution and warm water. Suitable proprietary chemical cleaners may be used only on enamel after first consulting the instructions supplied with the oven cleaner and testing a small sample on the oven cavity. Abrasive cleaning agents or scouring pads/cloths should not be used on the cavity surface.

NOTE: The manufacturers of this appliance will accept no responsibility for damage caused by chemical or abrasive cleaning.

Let the oven cool down and pay special attention not to touch the hot heating elements inside the oven cavity.

BURNERS AND PAN SUPPORTS

These parts can be removed and cleaned as indicated previously.

After cleaning, the burners and their flame spreaders must be well dried and correctly replaced.

It is very important to check that the burner flame spreader and the cap have been correctly positioned. Failure to do so can cause serious problems.

Check that the electrode “**S**” (figs. 8.1, 8.3) next to each burner is always clean to ensure trouble-free sparking.

Check that the probe “**T**” (figs. 8.1, 8.3) next to each burner is always clean to ensure correct operation of the safety valves.

Both the probe and ignition plug must be very carefully cleaned.

Note: To avoid damage to the electric ignition do not use it when the burners are not in place.

CORRECT REPLACEMENT OF THE AUXILIARY, SEMI-RAPID AND RAPID BURNERS

It is very important to check that the burner flame distributor “**F**” and the cap “**C**” have been correctly positioned (see figs. 8.1, 8.2) - failure to do so can cause serious problems.

REPLACING THE OVEN LIGHT BULB

Switch the cooker off at the mains.

When the cooker is cool unscrew and replace the bulb with another one resistant to high temperatures (300°C), voltage 230V, 50 Hz, type E14 and same power (check watt power as stamped in the bulb itself) of the replaced bulb.

Note: Oven bulb replacement is not covered by your guarantee.

CORRECT REPLACEMENT OF THE TRIPLE RING BURNER

The triple ring burner must be correctly positioned (see fig. 8.5); the burner rib must be enter in their logement as shown by the arrow (see fig. 8.3).

Then position the cap “**A**” and the ring “**B**” (figs. 8.4, 8.5).

The burner correctly positioned must not rotate (fig. 8.4).

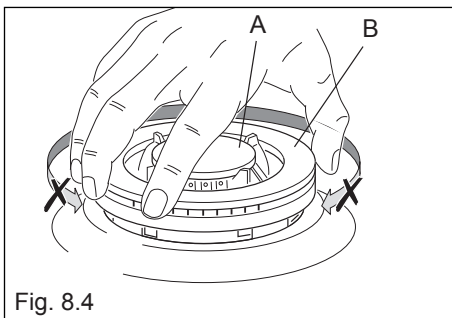
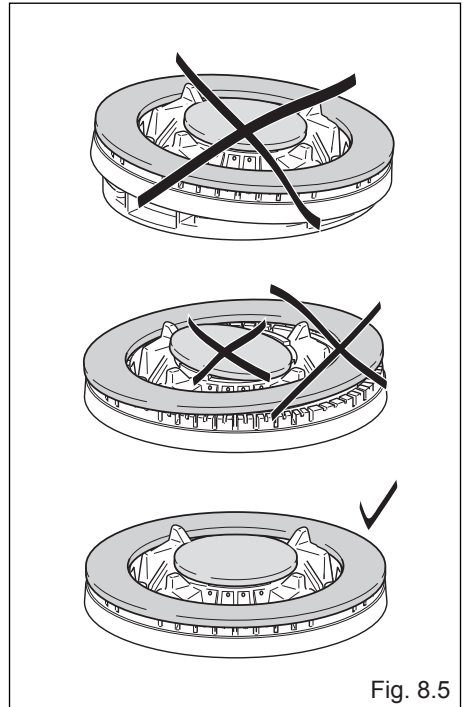
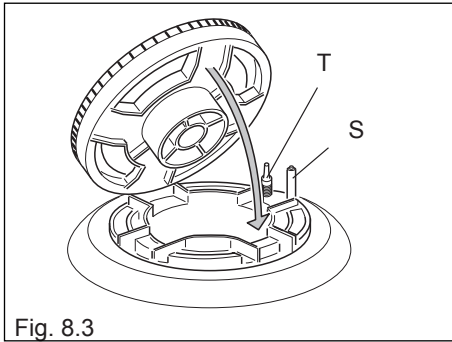
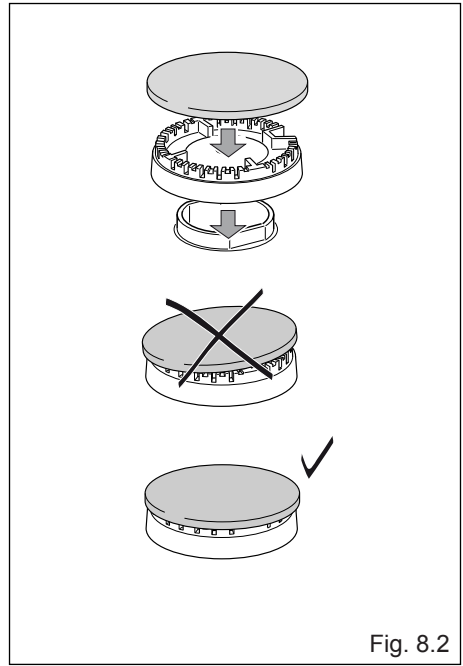
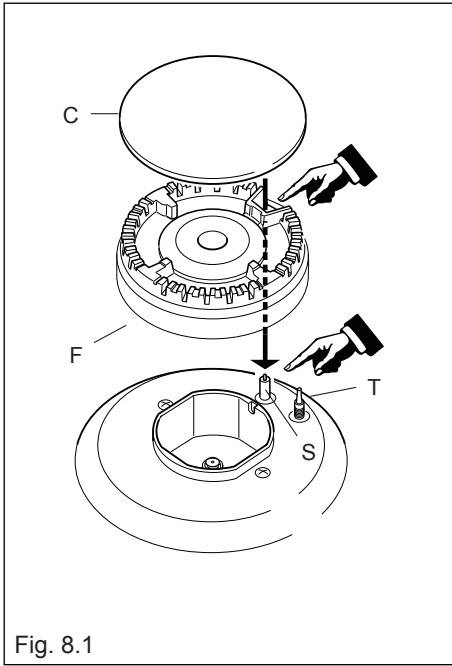

ASSEMBLING AND DISMANTLING OF THE SIDE RUNNER FRAMES

- Assemble the wire racks to the oven walls using the 2 screws (figs. 8.6a - 8.6b).
- Slide the tray and rack into the runners (figs. 8.7a - 8.7b).
The rack must be fitted so that the safety notch, which stops it sliding out, faces the inside of the oven; the guard rail should be at the back.
- To dismantle, operate in reverse order.

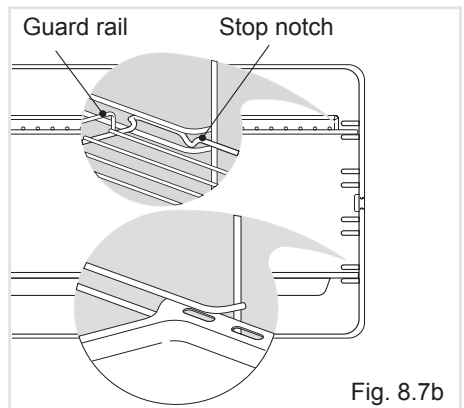
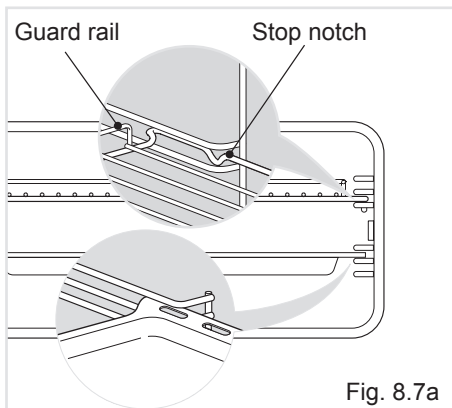
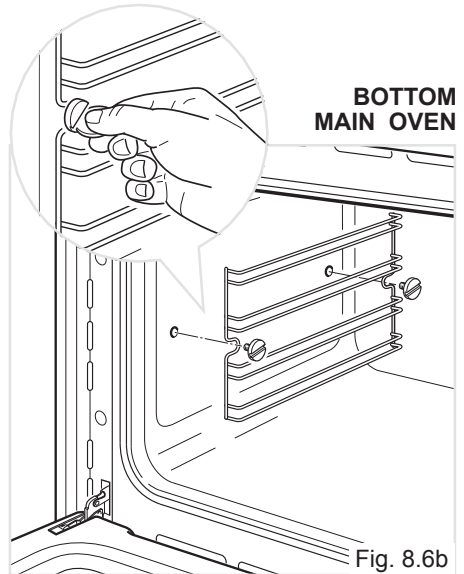
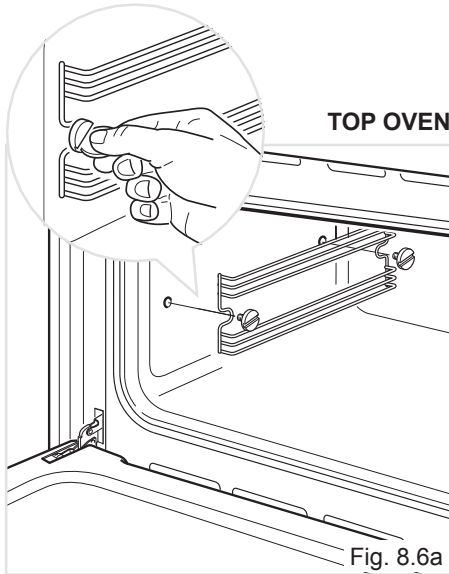

REPLACING THE HALOGEN OVEN LIGHT

WARNING: Ensure the appliance is switched off before replacing the lamp to avoid the possibility of electric shock.

- Let the oven cavity and the heating elements cool down;
- Switch off the electrical supply;
- Remove the protective cover "C" (fig. 8.8);
- Replace the halogen lamp "B" with a new one suitable for high temperatures having the following specifications: 230V and same power (check watt power as stamped in the lamp itself) of the replaced lamp.

IMPORTANT WARNING: Never replace the bulb with bare hands; contamination from your fingers can cause premature failure. Always use a clean cloth or gloves.

- Refit the protective cover;

Note: Oven bulb replacement is not covered by your guarantee.

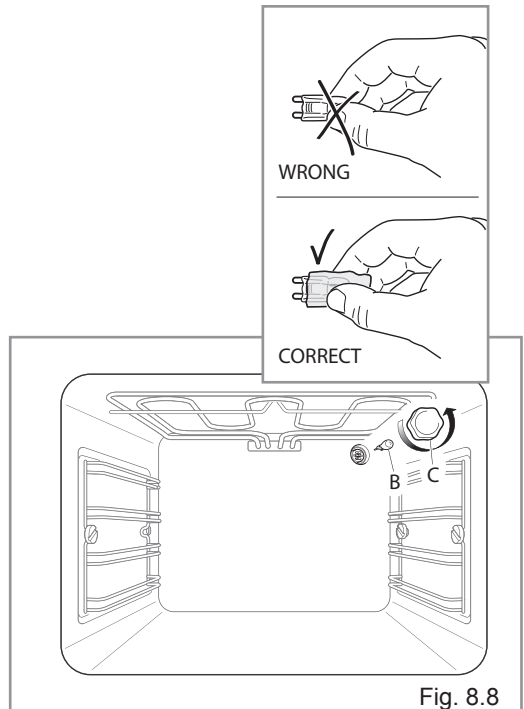
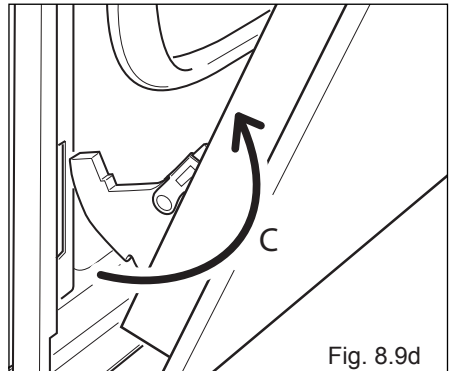
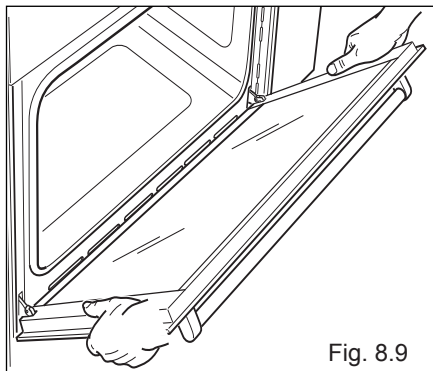
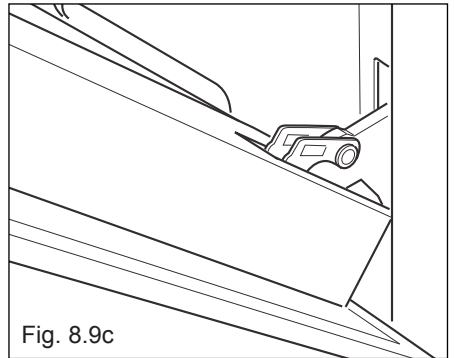
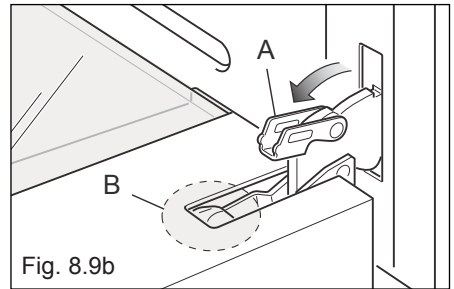
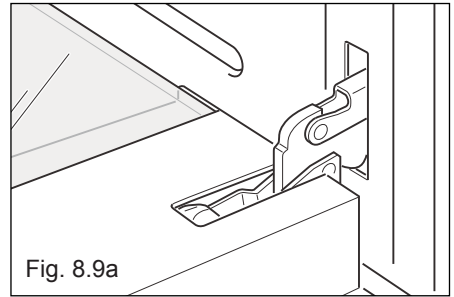

Fig. 8.8

TOP OVEN DOOR REMOVING THE OVEN DOOR

The oven door can easily be removed as follows:

- Open the door to the full extent (fig. 8.9a).
- Open the lever "A" completely on the left and right hinges (fig. 8.9b).
- Hold the door as shown in fig. 8.9.
- Gently close the door (fig. 8.9c) until left and right hinge levers "A" are hooked to part "B" of the door (fig. 8.9b).
- Withdraw the hinge hooks from their location following arrow "C" (fig. 8.9d).
- Rest the door on a soft surface.
- To replace the door, repeat the above steps in reverse order.



TOP OVEN DOOR REMOVING THE INNER PANE OF GLASS

The oven door has two panes. To clean these, you need to remove the inner pane.

1. Lock the door open:
 - Fully open the oven door (fig. 8.10a).
 - Fully open the lever "A" on the left and right hinges (fig 8.10b).
 - Gently close the door (fig. 8.10c) until the left and right hinges are hooked to part "B" of the door (fig. 8.10b).
2. Remove the inner pane:
 - Gently pull out the inner pane of glass (fig. 8.10).
 - Clean the glass with an appropriate cleaner. Dry thoroughly, and place on a soft surface. Now you can also clean the inside of the outer glass.

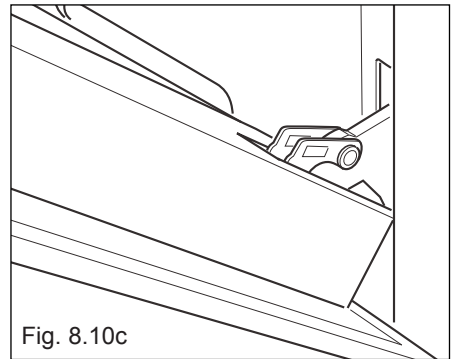
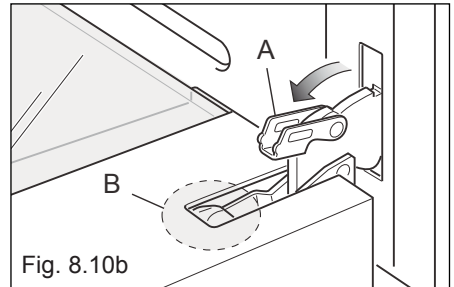
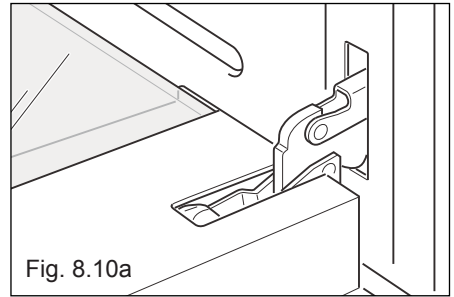

CLEANING THE PANES OF GLASS

Do not use harsh abrasive cleaners or sharp metal scrapers to clean the oven door glass since they scratch the surface, which may result in shattering of the glass.

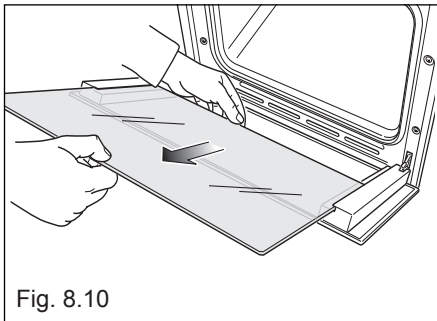

TOP OVEN DOOR REPLACING THE INNER PANE OF GLASS

1. Make sure the door is locked open (see previous page).
2. Replace the inner pane:
 - Check that the four rubber pads are in place (“D” in fig. 8.11a).
 - Check that you are holding the pane the correct way. You should be able to read the wording on it as it faces you.
 - Insert the pane in the left “E” and right “F” slide guides (fig. 8.11b), and gently slide it to the retainers “H” (fig. 8.11c).
 - Unlock the oven door by opening it completely and closing the lever “A” on the left and right hinges (fig. 8.11).

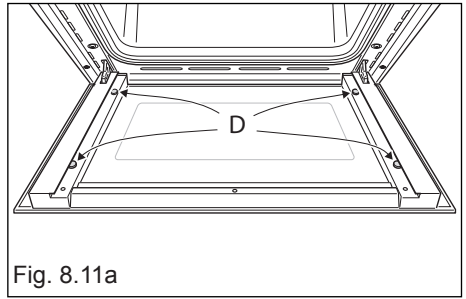

Fig. 8.11a

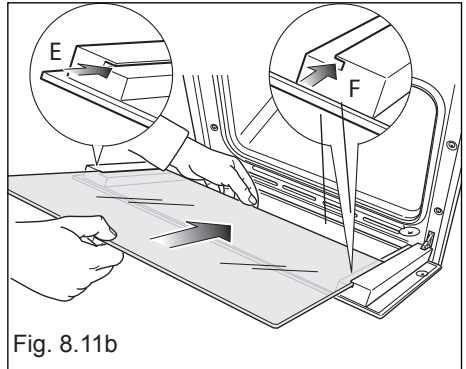

Fig. 8.11b

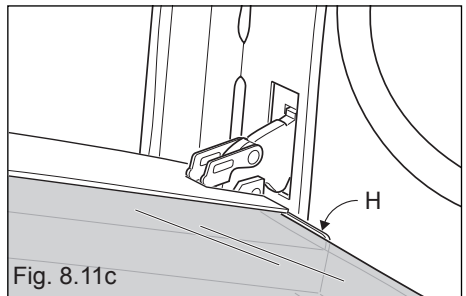

Fig. 8.11c

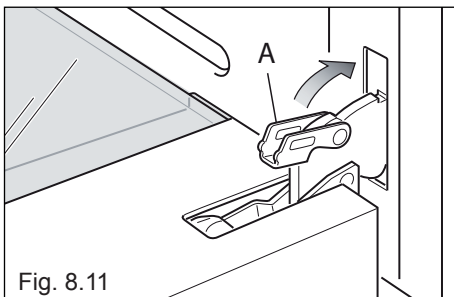

Fig. 8.11

BOTTOM OVEN DOOR

Note: The oven door should only be removed by an authorised service agent.

Removal of the oven door by a non-authorised person will invalidate the guarantee.

BOTTOM OVEN DOOR REMOVING THE INNER PANE OF GLASS

When removing and replacing the inner glass, the door should be held still by one person (fig. 8.12). A second person should gently remove the glass (fig. 8.13).

The oven door has two panes. To clean these, you need to remove the inner pane.

- Open the oven door.
- Gently pull out the inner pane of glass (fig. 8.13). Forcible removal of the door glass may lead to damage of the door hinges.
- Clean the glass with an appropriate cleaner. Dry thoroughly, and place on a soft surface. Now you can also clean the inside of the outer glass.

CLEANING THE PANES OF GLASS

Do not use harsh abrasive cleaners or sharp metal scrapers to clean the oven door glass since they scratch the surface, which may result in shattering of the glass.

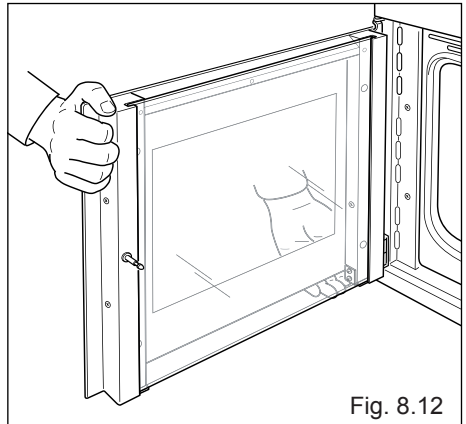

Fig. 8.12

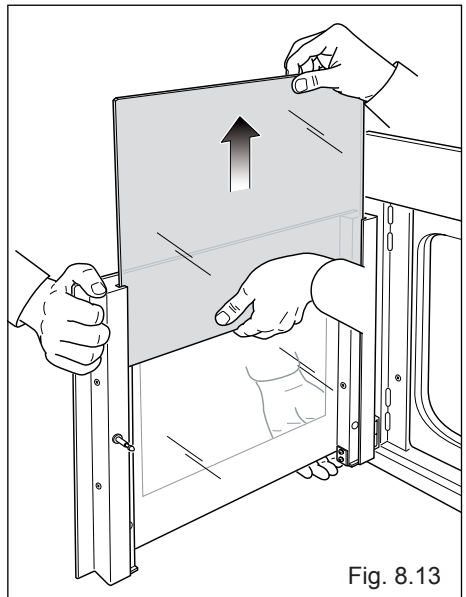

Fig. 8.13

BOTTOM OVEN DOOR REPLACING THE INNER PANE OF GLASS

To replace the inner pane of the door operate as follows:

- Check that the four rubber pads are in place (“D” in fig. 8.14).
- Check that you are holding the pane the correct way. You should be able to read the wording on it as it faces you.
- Whilst one person holds the door still, a second person should insert the inner pane in the left “E” and right “F” side guides (fig. 8.15) and gently let it slide up to the retainers “H” (fig. 8.16). Forcible replacement of the door glass may lead to damage of the door hinges.

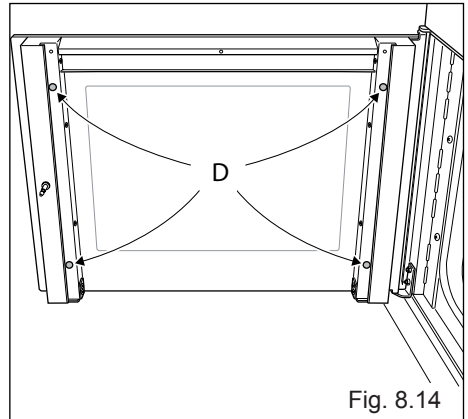

Fig. 8.14

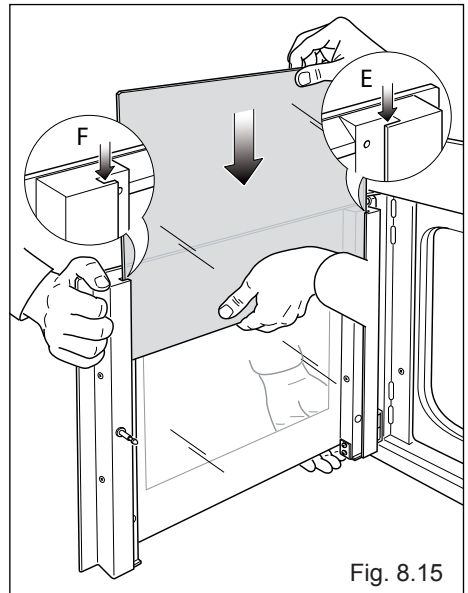

Fig. 8.15

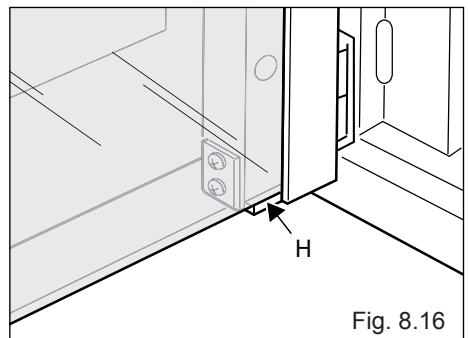

Fig. 8.16

Advice for the installer

IMPORTANT

- The appliance is designed and approved for domestic use only and should not be installed in a commercial, semi commercial or communal environment.
Your product will not be guaranteed if installed in any of the above environments and could affect any third party or public liability insurances you may have.
The appliance may be installed in a kitchen, kitchen/diner or a bed sitting room, but not in a room or space containing a bath or a shower without first consulting current regulations.
The appliance must not be installed in a bed-sitting room of less than 20 m³.
- Cooker installation must only be carried out by a **SUITABLY QUALIFIED AND REGISTERED TECHNICIAN** and in compliance with local safety standards.
Failure to observe this rule will invalidate the warranty.
- The appliance must be installed in compliance with regulations in force in your country and in observation of the manufacturer's instructions.
- Always disconnect the appliance from the power supply before carrying out any maintenance operations or repairs.
- Take care NOT to lift the oven by the door handle/s.
- Some appliances are supplied with a protective film on steel and aluminium parts.
This film must be removed before using the cooker.
- **Important: The use of suitable protective clothing/gloves is recommended when handling or installing this appliance.**

WARNING

When correctly installed, your product meets all safety requirements laid down for this type of product category. However special care should be taken around the rear or the underneath of the appliance as these areas are not designed to be touched and may contain sharp or rough edges, that may cause injury.

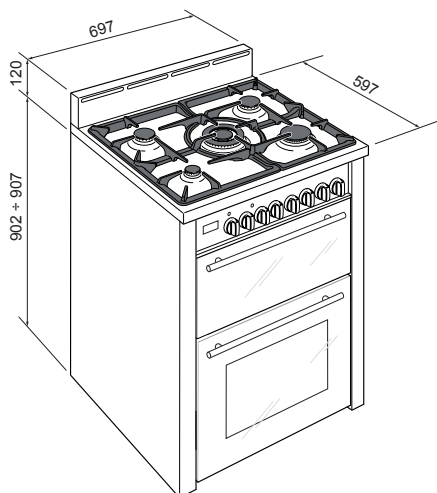

This cooker has class “2/1” overheating protection so that it can be installed next to a cabinet.

If the cooker is installed adjacent to furniture which is higher than the gas hob cooktop, a gap of at least 200 mm must be left between the side of the cooker and the furniture.

The walls and kitchen furniture surrounding the appliance must be made of non-flammable material. The veneered synthetical material and the glue used must be resistant to a temperature of 90°C in order to avoid ungluing or deformations. It is recommended that a 10 mm gap to each side is made if the adjacent kitchen furniture is made of a plastic laminate wrap.

Curtains must not be fitted immediately behind appliance or within 500 mm of the sides.

It is essential that the cooker is positioned as stated below.

We do not recommend the cooker is located on a plinth. If this is unavoidable, it will be necessary to provide safety measures to prevent the appliance falling off.

The cooker must be installed by a suitably qualified technician and in compliance with local safety standards.

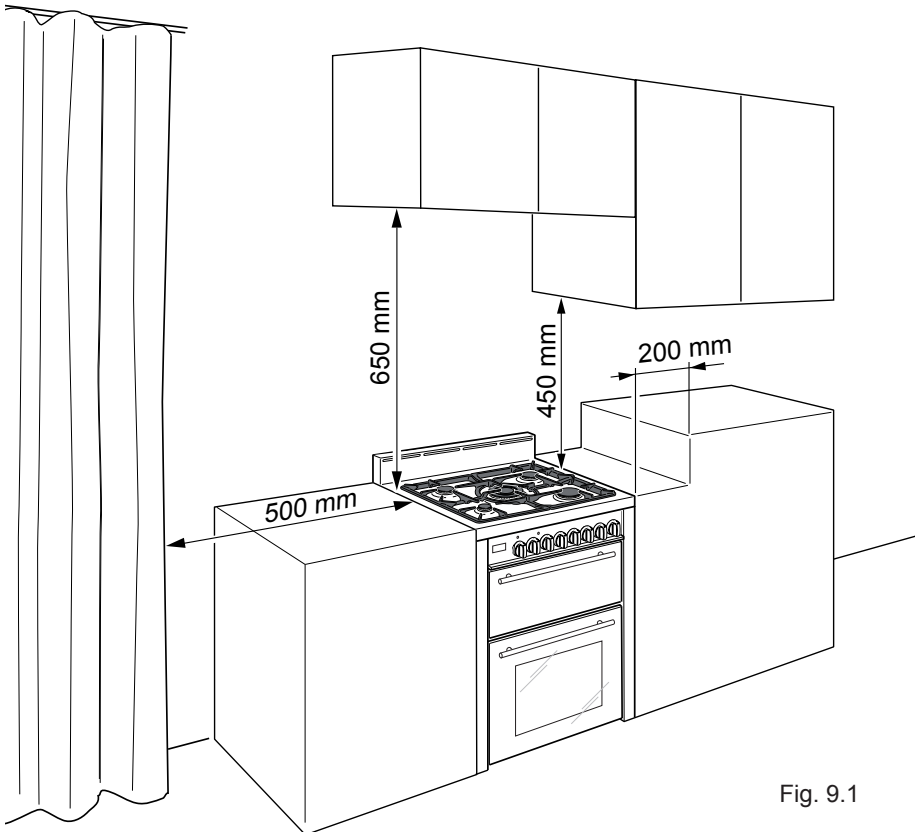

Fig. 9.1

Before installing the cooker level the appliance by screwing or unscrewing the four adjustable feet fitted below.

WARNING!

For safety reasons unscrew the feet (from screwed position) to the maximum extent of 5 mm (fig. 9.2).

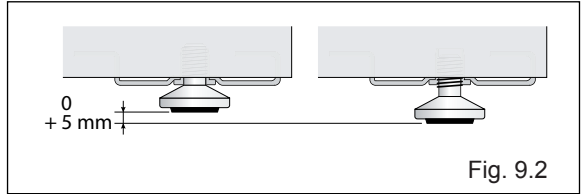

Fig. 9.2

BACKGUARD

- Remove the screws “A” from the rear of the cooktop.
- Assemble the backguard as shown in fig. 9.3 and fix it by screwing the no.3 screws “A”.

It is mandatory to install the backguard.

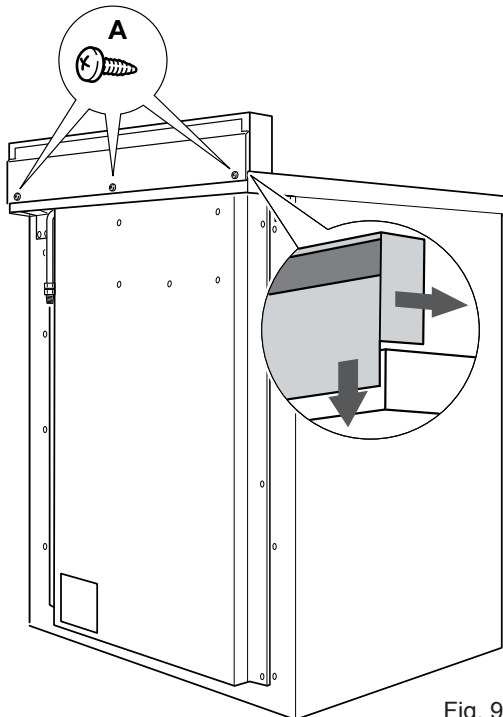
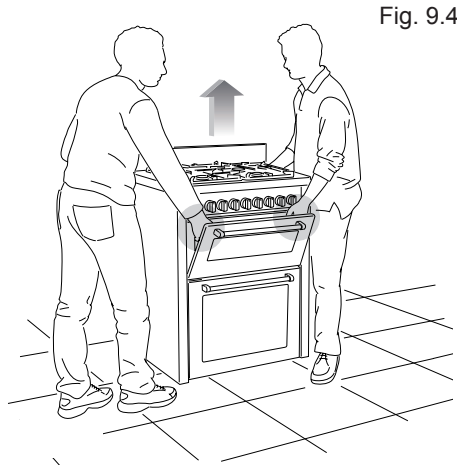

Fig. 9.3

MOVING THE COOKER

WARNING: When raising cooker to upright position always ensure two people carry out this manoeuvre to prevent damage to the adjustable feet (fig. 9.4).



WARNING

Be careful: do not lift the cooker by the door handle when raising to the upright position (fig. 9.5).

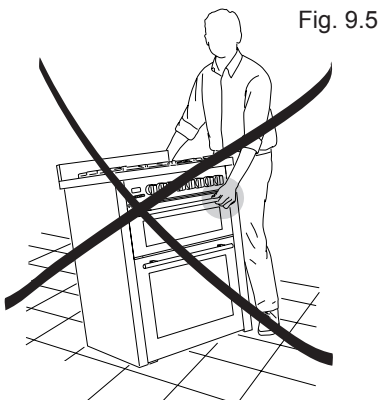

WARNING

When moving cooker to its final position DO NOT DRAG (fig. 9.6). Lift feet clear of floor (fig. 9.4).

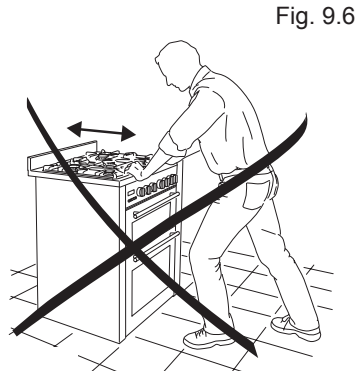

ANTI-TILT BRACKET

Important!

To restrain the appliance and prevent it tipping accidentally, the anti-tilt bracket supplied must be fitted according to the instructions below.

To fit the anti-tilt bracket:

1. After you have located where the cooker is to be positioned, mark on the wall and on the floor the place where the four screws of the anti-tilt bracket have to be fitted. Please follow the indications given in fig. 9.7.
2. Drill four 8mm diameter holes for the fixing screws (two in the wall and two in the floor—see fig. 9.7) and insert the plastic plugs supplied.

Important!

Before drilling the holes, check that you will not damage any pipes or electrical wires.

3. Attach the anti-tilt bracket to the floor and rear wall using the four screws supplied, as shown in fig. 9.7.
4. After attaching the anti-tilt bracket securely, slide the cooker into place. Ensure that the rear left foot slides under the bracket, as shown in fig. 9.7.

Attention!

When sliding the cooker into place pay special not to trap the power supply cable in the stability bracket.

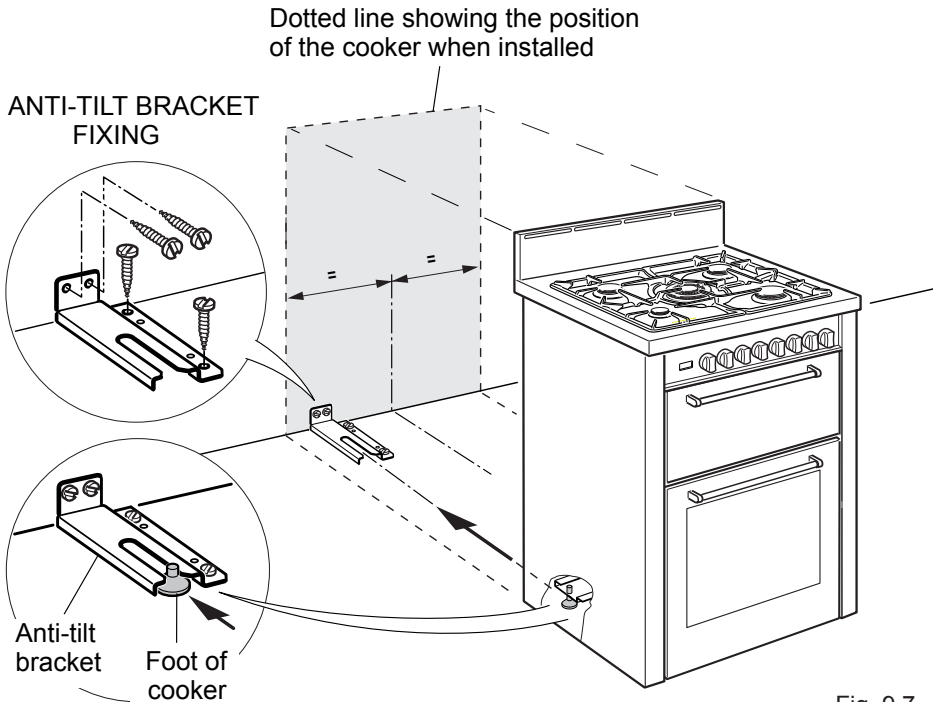

Fig. 9.7

PROVISION FOR VENTILATION

- The appliance should be installed into a room or space with an air supply in accordance with the current version of BS 5440-2: 2000.
- For rooms with a volume of less than 5m³ - permanent ventilation of 100 cm² free area must be provided.
- For rooms with a volume of between 5 m³ and 10 m³ a permanent ventilation of 50 cm² free area will be required unless the room has a door which opens directly to the outside air in which case no permanent ventilation is required.
- For rooms with a volume greater than 10 m³ - no permanent ventilation is required.

Note: Regardless of room size, all rooms containing the appliance must have direct access to the outside air via an openable window or equivalent.

- Where there are other fuel burning appliances in the same room, the current version of BS 5440-2: 2000 should be consulted to determine the correct amount of free area ventilation requirements.

IMPORTANT NOTE

This appliance is supplied for use on NATURAL GAS or LPG (check the gas regulation label attached on the appliance).

- Appliances supplied for use on NATURAL GAS are adjusted for this gas only and cannot be used on any other gas (LPG) without modification. The appliances are manufactured for conversion to LPG.
- Appliances supplied for use on LPG are adjusted for this gas only and cannot be used on any other gas (NATURAL GAS) without modification. The appliances are manufactured for conversion to NATURAL GAS.

If the NATURAL GAS/LPG conversion kit is not supplied with the appliance this kit can be purchased by contacting the After-Sales Service.

INSTALLATION & SERVICE REGULATIONS (UNITED KINGDOM)

It is a legal requirement that all gas appliances are Installed & Serviced by a competent person in accordance with the current editions of the following Standards & Regulations or those regulations appropriate to the geographical region in which they are to be installed:

- Gas Safety (Installation & Use) Regulations
- Building Regulations
- British/European Standards
- Regulations for Electrical Installation

Installation and service of any gas product must be made by a suitably qualified and registered person competent on the type of product being installed or serviced and holding a valid certificate of competence for the work being carried out. Currently the proof of competence is the Accredited Certification Scheme (ACS) or N/SVQ that has been aligned to the ACS.

It is also a requirement that all businesses or self employed installers are members of a class of person approved by the Health and Safety Executive.

Failure to install the appliance correctly could invalidate any manufacturers warranty and lead to prosecution under the above quoted regulations.

GAS CONNECTION



Cat: II 2H 3+

It is a requirement that a restraining chain (not supplied with the appliance) is also used to prevent stress being applied to the gas hose or pipework. The chain should be attached securely to the product and on the wall (fig. 10.1).

RESTRAINING CHAIN

Fig. 10.1

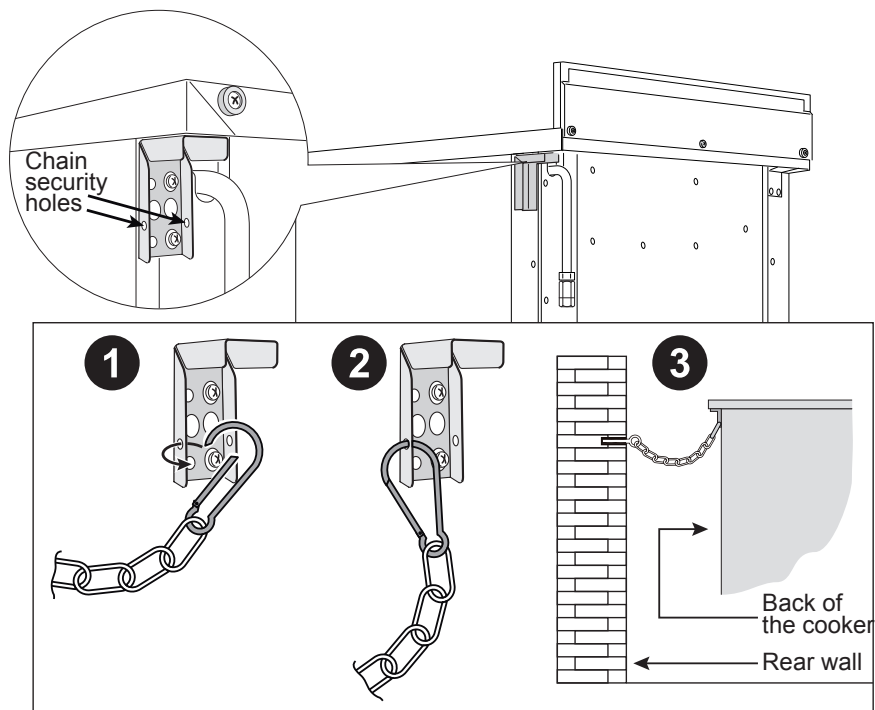

Installation to Natural Gas

Installation to Natural Gas must conform to the Code of Practice, etc.

The supply pressure for Natural Gas is 20 mbar.

The installation must conform to the relevant British/European Standards.

Installation to LP Gas

When operating on Butane gas a supply pressure of 28-30 mbar is required.

When using Propane gas a supply pressure of 37 mbar is required.

The installation must conform to the relevant British/European Standards.

Warning: Only a suitably qualified and registered installer, also with technical knowledge of electricity should install the appliance.

He should observe the Regulations and Codes of Practice governing such installation of gas appliances.

Note: It is recommended that the gas connection to the appliance is installed with a flexible hose connecting tube made to BS669.

Notes:

- Flexible hoses can be used where the sited ambient temperature of the hose does not exceed 70°C. These hoses must be manufactured in accordance with BS669 part 1 and be of the correct construction for the type of gas being used.
- Gas hoses designed for natural gas **MUST NOT** be used for supplying LPG gas (LPG gas hoses can be identified by either a red band or stripe on the rubber outer coating of the hose).
The hose should not be crushed or trapped or be in contact with sharp or abrasive edges.

IMPORTANT! It is the responsibility of the gas installer to ensure that the product is fully tested and commissioned in accordance with current regulations to ensure there are no gas escapes.

Gas connection (figs. 10.2, 10.3, 10.4)

- The gas supply must use the gas inlet pipe which is located at the left hand side at the rear of the appliance.
- **IMPORTANT NOTE:** Before connecting the appliance to the gas mains fit the female connector (supplied with the appliance in a separate kit) to the left inlet pipe using the fibre washer supplied.

IMPORTANT: Check the correct positioning of the connector as per pictures and **always operate using two suitable spanners.**

- The hose should not be crushed or trapped or be in contact with sharp or abrasive edges. It should also not be subjected to corrosion by acidic cleansing agents.
The hose should also be connected in such away that it does not touch the floor and must hang in a natural loop between the appliance and the bayonet fitting.
- To avoid damage to the appliance gas rail inlet pipe the fittings should be tightened using two suitable spanners.

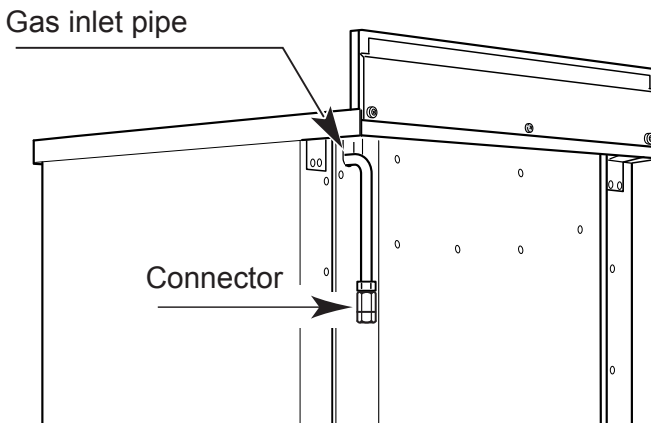
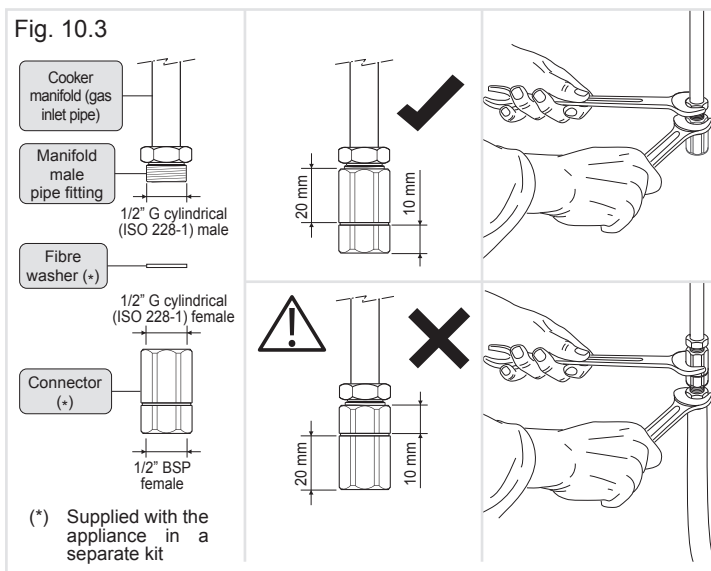

Fig. 10.2



IMPORTANT PRESCRIPTIONS FOR GAS CONNECTION

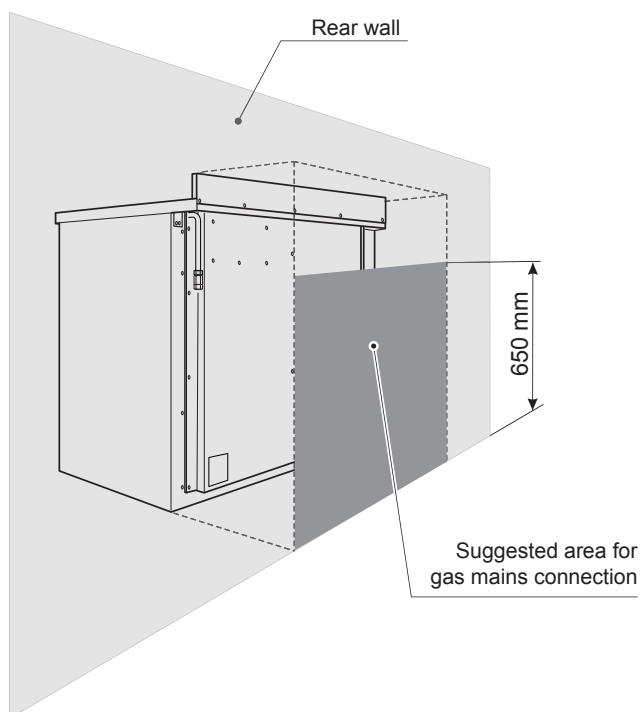

Fig. 10.4

Conversion to Natural Gas or to LPG

REPLACEMENT OF THE INJECTORS OF THE TOP BURNERS

If the injectors are not supplied they can be obtained from the After-Sales Service.

Select the injectors to be replaced according to the "Table for the choice of the injectors".

The nozzle diameters, expressed in hundredths of a millimetre, are marked on the body of each injector.

To replace the injectors proceed as follows:

- Remove pan supports and burners from the cooktop.
- Using a wrench, substitute the nozzle injectors "J" (figs. 10.5, 10.6) with those most suitable for the kind of gas for which it is to be used.

The burners are conceived in such a way so as not to require the regulation of the primary air.

ADJUSTING OF THE MINIMUM OF THE TOP BURNERS

In the minimum position the flame must have a length of about 4 mm and must remain lit even with a quick turn from the maximum position to that of minimum.

The flame adjustment is done in the following way:

- Turn on the burner.
- Turn the tap to the MINIMUM position.
- Take off the knob.
- With a thin screwdriver turn the screw "F" until adjustment is correct (fig. 10.7).

Normally for LPG, tighten up the regulation screw.

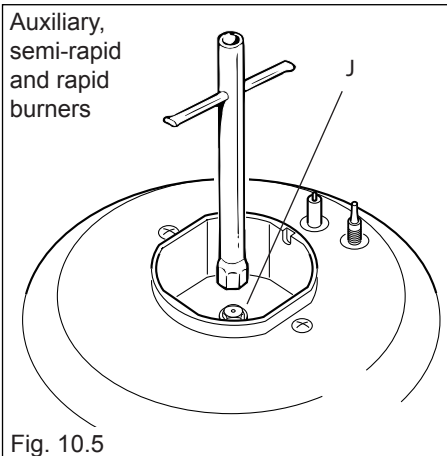

Fig. 10.5

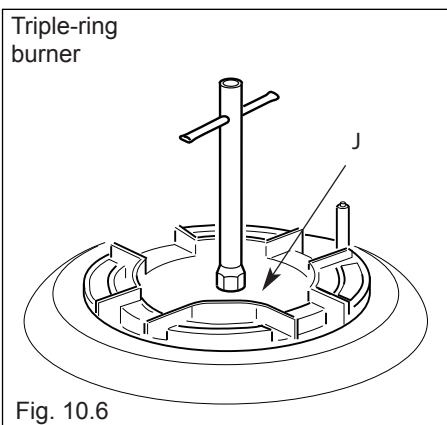

Fig. 10.6

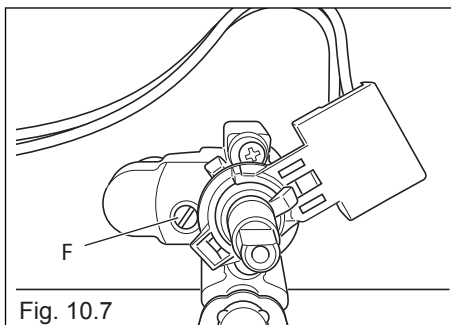

Fig. 10.7

TABLE FOR THE CHOICE OF THE INJECTORS

GB Cat: II 2H3+

BURNERS	Nominal power [kW]	Reduced power [kW]	LPG G30 28-30 mbar G31 37 mbar	Natural Gas G20 20 mbar
			∅ injector [1/100 mm]	∅ injector [1/100 mm]
Auxiliary (A)	1,00	0,30	50	72 (X)
Semi-rapid (SR)	1,75	0,45	65	97 (Z)
Rapid (R)	3,00	0,75	85	115 (Y)
Triple-ring (TR)	3,50	1,50	95	135 (T)

AIR VENT NECESSARY FOR GAS COMBUSTION = (2 m ³ /h x kW)	
BURNERS	Air necessary for combustion [m ³ /h]
Auxiliary (A)	2,00
Semi-rapid (SR)	3,50
Rapid (R)	6,00
Triple-ring (TR)	7,00

LUBRICATION OF THE GAS TAPS

- In case of difficulty in the gas taps operation, call Service.

IMPORTANT

All intervention regarding installation maintenance of the appliance must be fulfilled with original factory parts.

The manufacturer declines any liability resulting from the non-compliance of this obligation.

IMPORTANT: The appliance must be installed in accordance with the manufacturer's instructions. Incorrect installation, for which the manufacturer accepts no responsibility, may cause damage to persons, animals and property.

The connection of the appliance to earth is mandatory. The manufacturer declines all responsibility for any inconvenience resulting from the inobservance of this condition.

Before carrying out any work on the electrical parts of the appliance, the appliance must be disconnected and locked off from the mains.

The appliance must be connected to the electrical network verifying that the voltage corresponds to the value indicated on the specifications plate and that the cables section of the electrical wiring can bear the load which is indicated on the rating plate.

We recommend that the appliance is connected by a suitably qualified person who will comply with the current IEE and local regulations.

It is recommended that the appliance is connected via a dedicated cooker circuit using a double pole cooker switch with a rating equal or greater than the total loading of the cooker, with a minimum opening between the contacts of 3 mm.

Alternative connection methods may be available as long as they conform to current IEE wiring regulations.

The power supply cable must not touch the hot parts and must be positioned so that it does not exceed 75°C at any point.

Once the cooker has been installed, the switch must always be easily accessible within 2 metres.

ELECTRICAL FEEDER CABLE CONNECTION

WARNING: The power supply cable must be connected only by an authorised service agent in order to avoid a hazard.

To connect the feeder cable to the cooker it is necessary to:

- Remove the 2 screws that hold shield “A” behind the cooker.
- Open completely the cable clamp “D”.
- Insert the feeder cable into the cable save “P”. The supply cable must be of a suitable size for the current requirements of the appliance; see the section “Feeder cable section”.
- Connect the live, neutral and earth cables to terminal “B” according to figures 11.1 and 11.2.
- Pull the feeder cable and block it with the cable clamp “D”.
- Re-mount shield “A”.

Note: The earth conductor must be left about 3 cm longer than the others.

POWER SUPPLY

230 V~ 50 Hz 4295 W

FEEDER CABLE SECTION TYPE H05RRF

230 V~ 3 x 2.5 mm²

(*) Connection with wall box connection

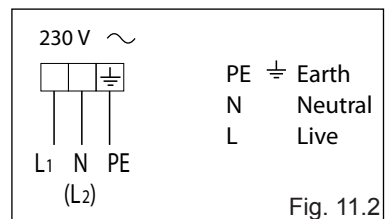
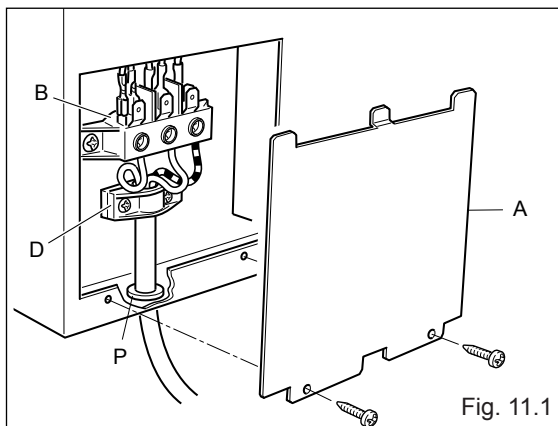

The manufacturer cannot be held responsible for possible inaccuracies due to printing or transcription errors in the present booklet.

The manufacturer reserves the right to make all modifications to its products deemed necessary for manufacture or commercial reasons at any moment and without prior notice, without jeopardising the essential functional and safety characteristics of the appliances.

The product specifications in this booklet apply to the specific products and models described at the date of issue. Under our policy of continuous product improvement, these specifications may change at anytime. You should therefore check with your dealer to ensure this booklet correctly describes the product currently available.

Main Dealer: www.rangecookers.co.uk

Service and Helpline Information:

tel: 01244 402 976

www.bigbluerangecookers.co.uk

Rangecookers Select 70df Twin User Guide

Products No: RCS70RCDFSS

Booklet No: 1104681 - B3